

# PSCAD/EMTDC Modeling/Analysis of VSC-HVDC Transmission for Cross Border Power System Interconnection

Jong-Yul Kim<sup>†</sup>, Jae-Young Yoon\* and Ho-Yong Kim\*

**Abstract** – When two adjacent AC systems operate at different frequency such as 50Hz and 60Hz, as in the case of ROK and Russia, the only way to practically obtain the advantages of power system interconnection is to use HVDC connection. In this paper, application of the VSC-HVDC transmission for power system interconnection between Russia and ROK is evaluated through the PSCAD/EMTDC modeling and analysis. The simulation results show the feasibility of proposed system for cross border power system interconnection.

**Keywords:** VSC-HVDC, PSCAD/EMTDC Modeling, Power System Interconnection

## 1. Introduction

The power system of ROK is like an island after having been isolated from the DPRK network in 1945 and therefore, there has never been any effort to connect it to power systems of neighboring countries.

Instead, all efforts have been focused on developing generating resources and enhancing the network in order to supply the power demand and to support the booming economy of the Republic of Korea during the last three decades. However, the Korean power industry has been confronted with many difficulties and will continue to be confronted in such a way in the future. Among the many reasons why the industry has faced such difficulties, the most important are as follows. Firstly, ROK is very poor in natural resources and must import 97.4% of the total primary energy domestically consumed. Secondly, ROK is a very small country and 70% of its territory is covered with mountains. Furthermore, due to military and political tension between ROK and DPRK until recently, there were many limitations to developing generating resources and expanding the network for supplying the heavy load in the northern part near Seoul. In this situation, one of the best ways to overcome such difficulties in supplying reliable power seems to be cross-border system interconnection. Especially, power system interconnection in the NEA (Near East Asia) region, so called NEAREST (Near East Asian Region Electrical System Tie), is under significant scrutiny recently [1-4]. When two adjacent AC systems operate at different frequency such as 50Hz and 60Hz, as in the case of ROK and Russia, the only way to practically obtain the advantages of power system interconnection is to use HVDC connection. HVDC system is the technology to inter-

connect two independent systems and actively control power transfer between two systems. HVDC system makes up of control, power conversion, and power system design technology. Usually, HVDC system can be analyzed by two different analysis methods. One is PSS/E and the other is PSCAD/EMTDC. PSS/E is to carry out the analysis in the viewpoint of the whole power system through power flow in steady states. PSCAD/EMTDC is a good analysis program to investigate transient and dynamic characteristic of HVDC system. In PSCAD/EMTDC analysis, system analysis technique of conventional CSC (Current Source Converter)-HVDC system has already reached the very high level [5]. Given the experiences gained by introducing Hae-Nam and Che-Ju HVDC system, system analysis method is well established in ROK. However, the newly rising system, VSC (Voltage Source Converter)-HVDC has no example of introduction in the country like in the cases of low level technology and experience of PSCAD/EMTDC analysis.

Therefore, in this paper, we developed PSCAD/EMTDC model for Russia-ROK power system interconnection, which applied VSC-HVDC to lay the foundation for PSCAD/EMTDC modeling and analysis technology, and we also investigated dynamic characteristics of VSC-HVDC system under various operating conditions to verify this model.

## 2. Configuration of the VSC-HVDC System

HVDC was developed from technologies used in industrial drive systems. In order to obtain ideas on how HVDC can be developed, it is important to follow what is happening in that area. In industrial drives, the PCC (Phase Commutated Converter) technology that is presently used in HVDC has now almost totally been replaced by VSC technology. The fundamental difference between these two technologies is that VSC requires additional components that can switch off the

<sup>†</sup> Corresponding Author: Korea Electrotechnology Research Institute (KERI), Changwon, 641-120, Korea (jykim@keri.re.kr)

\* Korea Electrotechnology Research Institute (KERI), Changwon, 641-120, Korea

current, and not only turn it on as is the case with the PCC. As in a VSC, the current can be switched off, and there is no need for a network to commute against it. In HVDC-applications it could also be of interest to use VSC technology in order to supply “dead” networks, which are areas that lack rotating machines, or “weak” power systems that have excessively low short circuit power [6-8].

In this paper, therefore, the VSC-HVDC system is applied to interconnect between Russia and ROK as shown in Fig. 1. Additional details are as follows:

- ±500kV two-terminal VSC-HVDC system is applied and consists of a bipolar system, which means that the power divides into two DC transmission lines respectively.
- Interconnection bus voltage is set to 1.0pu and receives the reactive power from capacitor banks and the converter itself. Each terminal has capacitor banks for filtering the high frequency noise, which is 10% of the converter rating.

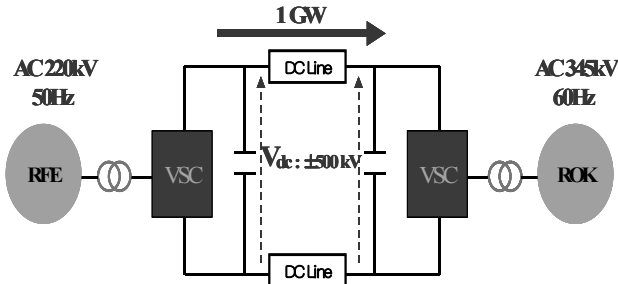

Fig. 1. Concept diagram of Russia-ROK power system interconnection

### 3. Steady-state Characteristics of VSC-HVDC Transmission

For the VSC shown in Fig. 2, assume that the fundamental phase of the voltage on the AC bus is  $V_{ac}$ , the fundamental phase of the voltage on the converter side of the VSC is  $V_{vsc}$ . The angle between  $V_{ac}$  and  $V_{vsc}$  is  $\delta$ . The reactance of the transformer is  $X$ .

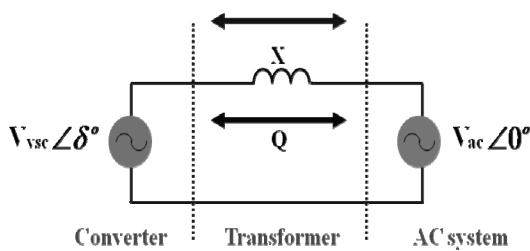

Fig. 2. Equivalent circuit between ac system and converter.

Ignoring the resistance of the transformer, the magnitude of the real and reactive power flowing over the VSC respectively are:

$$P = \frac{|V_{vsc}| |V_{ac}|}{X} \times \sin \delta \tag{1}$$

$$Q = \frac{|V_{vsc}| \cos \delta - |V_{ac}|}{X} \times |V_{ac}| \tag{2}$$

From (1), the magnitude of real power flowing over the VSC is determined primarily by  $\delta$ . The direction is determined by the relative position between  $V_{ac}$  and  $V_{vsc}$ .

When  $V_{vsc}$  lags behind  $V_{ac}$ , the VSC functions as a rectifier and absorbs real power from the AC system. When  $V_{vsc}$  takes the leading position, the VSC works as inverter and dispatches real power to AC system. Thus, by adjusting  $\delta$ , control over the amount of real power delivered via the VSC can be achieved. Normally, per unit value of  $X$  is in the range from 0.1pu to 0.3pu, and  $\delta$  is relatively small.

Hence, from (2), it is desirable to control  $Q$  by  $V_{vsc}$ . The direction is decided by the relative magnitude between  $V_{vsc}$  and  $V_{ac}$  as shown in Fig. 3 [9].

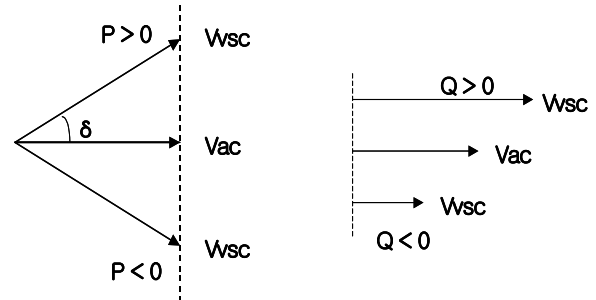

Fig. 3. Active and reactive power flow in according to magnitude and phase of converter output voltage.

### 4. PSCAD/EMTDC Modeling and Analysis

#### 4.1 VSC-HVDC Transmission System

In Fig. 4 represents the EMTDC equivalent model of the Russia-ROK power system interconnection.

VSC-HVDC system is bipolar system, which consists of equivalent 3 phase voltage sources, DC lines, transformers, two 6-pulse converters which play the role of Rectifier or Inverter.

##### a) AC Power System

Both AC systems are represented by 3-phase voltage source, which is described as equivalent voltage and equivalent impedance. Therefore, we can reflect the characteristics of AC system that will be connected with HVDC system by

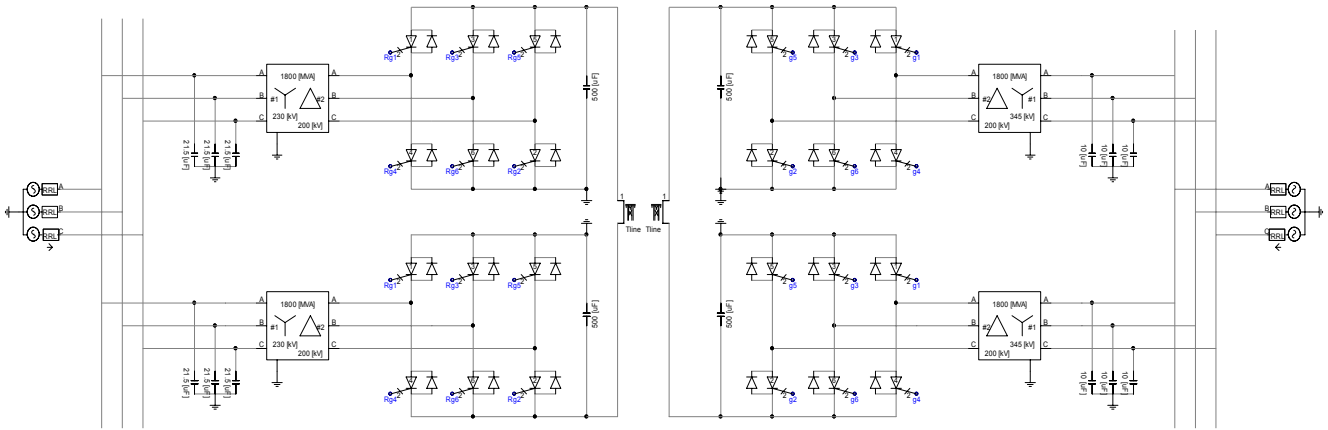

Fig. 4. PSCAD/EMTDC equivalent power system model

properly inputting parameters like equivalent impedance, voltage magnitude, phase and frequency.

**b) Converter**

In this study, we used 2 level, 6 pulse converters and constructed bipolar system with two of them. Each converter is made up of 6 IGBT, diode and snubber circuit.

**c) DC Transmission Line**

Provided that DC transmission line is an overhead transmission line, we use an overhead transmission line model in EMTDC library.

**d) Transformer**

In this study, 3-phase Y-Δ transformer is used as the converter transformer and saturation of transformer is not considered.

**4.2 Generating the Firing Pulse [10]**

PWM technique requires mixing the carrier signal with the fundamental frequency signal defining AC wave shape.

In this example, a sine wave is used to make it simplest signal to apply. Therefore, the PWM carrier signal is compared with the sine wave signal and both turn-on and turn-off pulses are generated for interpolated switching.

**a) Carrier Signal Generation**

Fig. 5 shows the EMTDC model for generating carrier signal. In this figure, phase locked oscillator synchronized to three phase AC system volts, one ramp output synchronized to phase A, ramping between 0° and 360° over one cycle of the fundamental frequency. The phase A 0° ~ 360° ramp is converted to PWM frequency, then to triangular signal between -1 and +1, and finally allocated to each valve for both interpolated switching turn-on and turn-off. The carrier signal generation process is as follows:

- i) Increases PLL ramp slope to the level required by carrier frequency.
- ii) Restrains ramps between 0° and 360° at carrier frequency.
- iii) Converts carrier ramps to carrier signals.

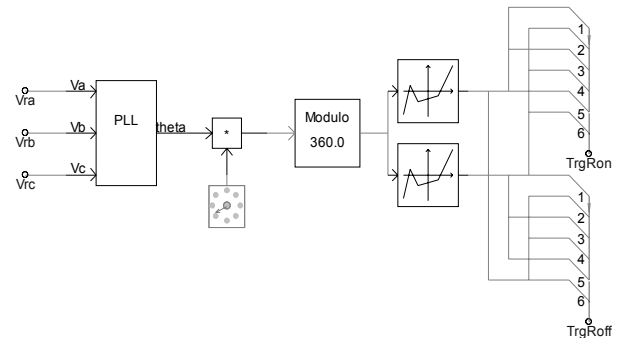

Fig. 5. Generating carrier signal model.

**b) Sine Wave Signal Generation**

Fig. 6 shows an EMTDC model for generating sine wave signal. As in the carrier signal generation, phase locked oscillator synchronized to three phase AC system volts. But, output are six ramps, 60° apart, ramping between 0° and 360° over one cycle of the fundamental frequency. The input ramp array signals from the PLL are phase-shifted 30° as well as by control input signal "sh\_ref". The ramps are converted to sine waves and their magnitudes are controlled by "m\_ref" input signal.

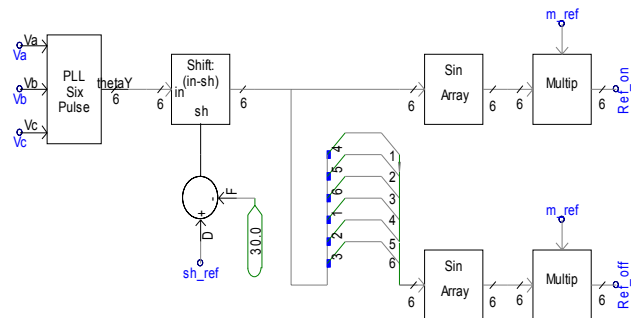

Fig. 6. Generating sine wave signal model.

**c) Firing Pulses Generation Module**

Carrier signal and sine waves are compared and at cross-over points, and generate turn-on and turn-off pulses for each IGBT valve. Fig. 7 presents an EMTDC module for generating firing pulses of IGBT valve.

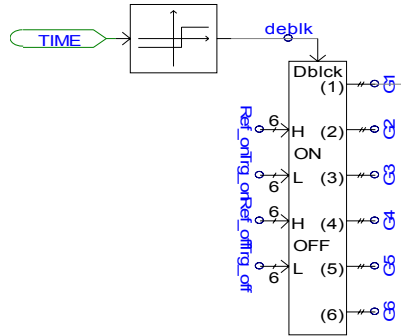

Fig. 7. Generating firing pulses of IGBT valve module.

**4.3 VSC Transmission Control Strategy [11]**

There is advantage to use pulse width modulation at VSC converters that have two parameters to be independently controlled. The parameters are the magnitude and the phase of the AC voltage generated on the VSC side of the interfacing reactor or transformer to the AC system. One successful control strategy for VSC transmission when located in system with AC voltage at each terminal is proposed by controlling the VSC side AC voltage at each converter as follows :

At the one VSC (rectifier) with PWM:

- DC link voltage is controlled by phase shift control
- AC system voltage is controlled by magnitude control

At the other VSC (inverter) with PWM:

- DC link power is controlled by phase shift control
- AC system voltage is controlled by magnitude control

**a) Rectifier Control**

① Control of DC Link Voltage

DC link voltage of VSC can be maintained by controlling charge on the large capacitors located on each side of the VSC. At rectifier, power flow into or out of the converter can be regulated to keep DC link voltage constant on the capacitors. A simple PI controller can control power flow by adjusting the phase shift angle "sh\_rec\_ref". The controller output "sh\_rec\_ref" signal is delivered to the sine wave generation part of rectifier. DC link voltage controller is shown in Fig. 8.

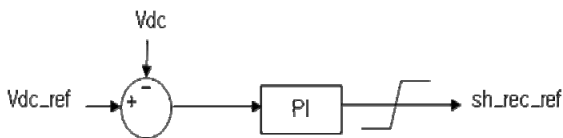

Fig. 8. DC link voltage controller at rectifier.

② Control of AC Voltage

A simple PI controller can be applied to regulated AC side voltages. The output of the PI controller adjusts the "m\_rec\_ref" signal to achieve its controlling function. The "m\_rec\_ref" signal is also delivered to the sine wave generation part of the rectifier with the signal "sh\_rec\_ref".

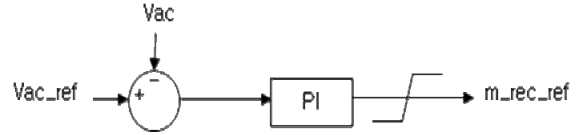

Fig. 9. AC voltage controller at rectifier.

**b) Inverter Control**

① Control of Power Flow in DC Line

The "sh\_rec\_ref" phase shift signal is used to control DC link voltage by controlling power into or out of the rectifier.

Another available "sh\_inv\_ref" signal at inverter can be applied to control power flow into or out of the AC system.

A simple PI controller also can control power flow by adjusting phase shift angle "sh\_inv\_ref". The controller output "sh\_inv\_ref" signal is delivered to the sine wave generation part of the inverter. Active power controller is shown in Fig. 10.

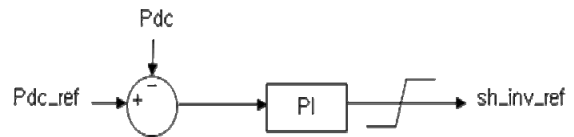

Fig. 10. Active power controller at inverter.

② Control of AC Voltage

Controlling AC voltages at the inverter is just like controlling at the rectifier. Therefore, the simple PI controller also can be applied to regulate the AC side voltage. The "m\_inv\_ref" signal is also delivered to the sine wave generation part with the signal "sh\_inv\_ref".

**5. Simulation Results**

We evaluate dynamic characteristics of VSC-HVDC system under various operating conditions such as AC power system fault as well as steady state, changing DC power flow, and AC voltage. In Table 1, Case 1 is initial stage of VSC-HVDC system, which Russia supply power of 0.5pu(500MW) to ROK. Fig. 11 shows the results of simulation such as DC link voltage, power flow in DC line, and AC voltages. The rectifier at Russia side starts at 0.3sec and then the inverter at ROK also starts at 0.6sec as shown in Fig. 11(a). The VSC-HVDC system reaches to the steady state at 1.8sec after the transient state. In the steady state, DC link voltage 500kV(1.0pu) and AC voltages are 1.0pu (220kV at

Russia, 345kV at ROK). In Case 2, commands of power flow in DC line and AC voltage of ROK bus changes from 0.5pu and 1.0pu to 0.8pu and 1.1pu at 0.5sec. Fig. 12 shows the results of the simulation in which the power flow in DC line and AC voltage of ROK bus reaches to the steady state at 0.9 sec after the transient state for 0.4sec. DC link voltage and AC voltage are changed a little during the transient state, but they reach the steady state shortly after the transient state as shown in Fig. 12(b)-12(d). Case 3 and 4 analyze the dynamic characteristics of VSC-HVDC system when a fault occurs at the both AC power systems.

In this study, we simulated that the magnitude of equivalent voltage source dropped for 0.1sec when fault occurs, meaning that AC voltage dropped due to the AC system fault. Fig. 13 and Fig. 14 represent power flow in DC transmission line, both AC bus voltage and DC link voltage when equivalent voltage drops due to the fault at the parts of Russia and ROK. As the fault is removed within 0.1sec, AC bus voltage returns to steady state passing through transient state like DC transmission power and DC link voltage.

**Table 1.** Operating condition of simulation cases.

Case	Operating conditions
Case 1	Power from Russia to ROK: 0.5pu AC voltage of Russia and ROK: 1.0pu
Case 2	Power from Russia to ROK: 0.5pu→0.8pu AC voltage of ROK: 1.0pu→1.1pu
Case 3	Fault in Russia AC System (Magnitude of voltage source 0.6pu)
Case 4	Fault in ROK AC System (Magnitude of voltage source 0.6pu)

### 6. Conclusion

As every country has different system frequency, HVDC system is the ultimate choice for NEAREST. For example, Russia and China have frequency of 50Hz but South and North Korea have 60Hz. So, it is impossible to apply the synchronous interconnection. HVDC system suits well to interconnect two or more systems with different system frequency and long distance transmission lines. The conventional HVDC system has applied CSC technology but the application has limits due to its structural problems like commutation failures. Besides, it is very difficult to apply HVDC system to the isolated power system with no generator and to weak power system with small SCR of AC system. Thanks to the rapid development of power electronic devices such as GTO and IGBT, VSC-HVDC is quite attracting the attention recently. VSC-HVDC has several advantages like independent control of active/reactive power and power supply to passive AC networks such as load on an island. In the PSCAD/EMTDC analysis field, system analysis method of conventional CSC-HVDC system has already reached the

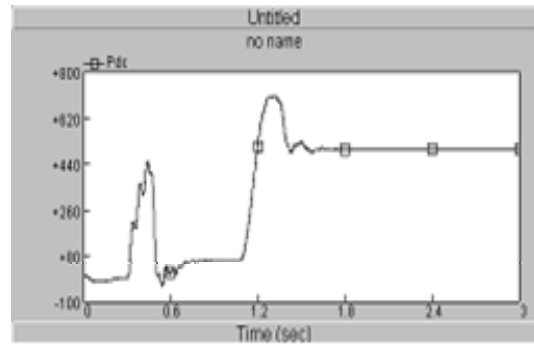

(a) Power flow in DC line (MW)

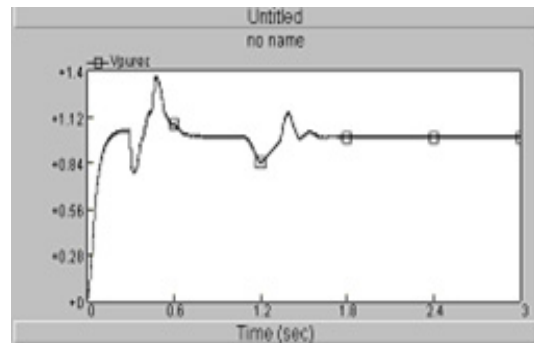

(b) AC voltage at Russia (pu)

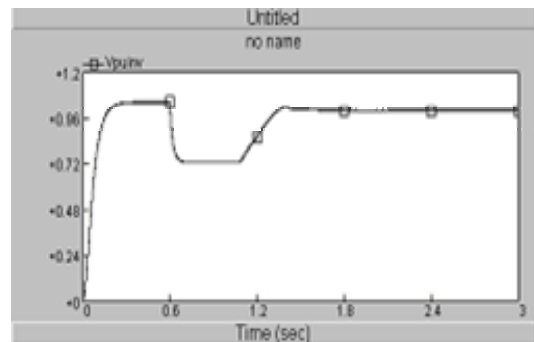

(c) AC voltage at ROK (pu)

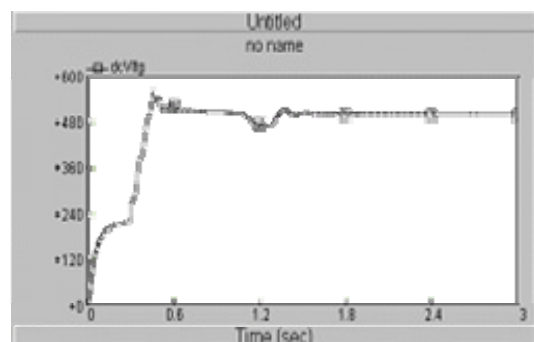

(d) DC link voltage (kV)

**Fig. 11.** Results of Case 1.

very high level and has mostly been established. However, there is no example of VSC-HVDC system introduction in the country yet and, in particular, the country lacks experience

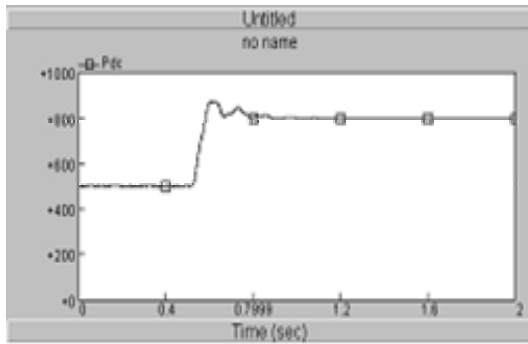

(a) Power flow in DC line (MW)

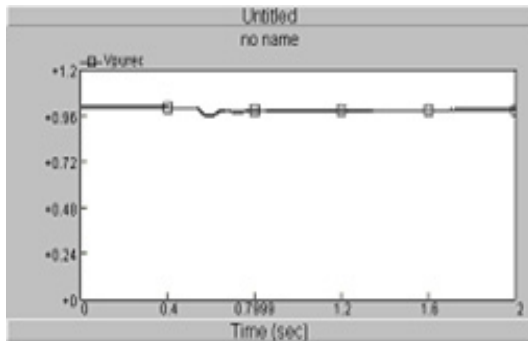

(b) AC voltage at Russia (pu)

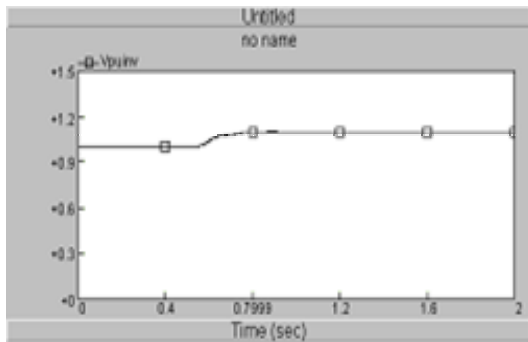

(c) AC voltage at ROK (pu)

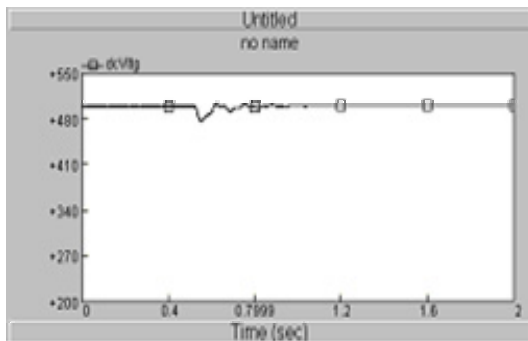

(d) DC link voltage (kV)

**Fig. 12.** Results of Case 2.

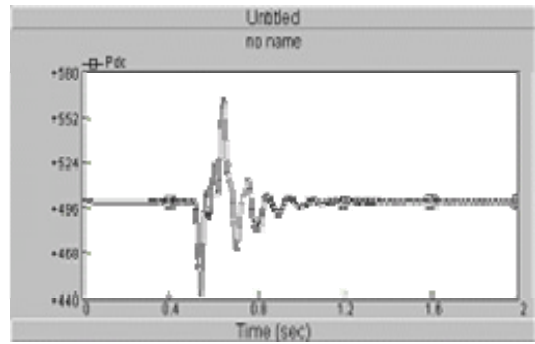

(a) Power flow in DC line (MW)

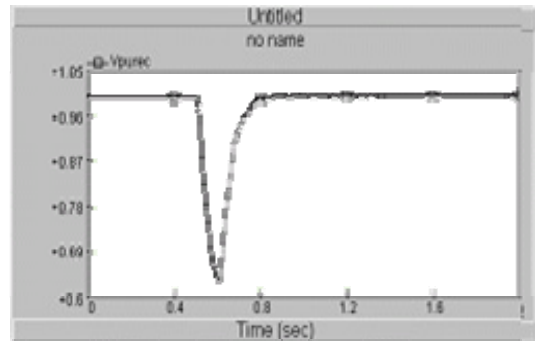

(b) AC voltage at Russia (pu)

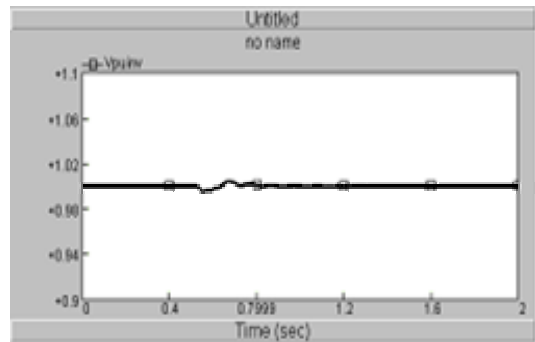

(c) AC voltage at ROK (pu)

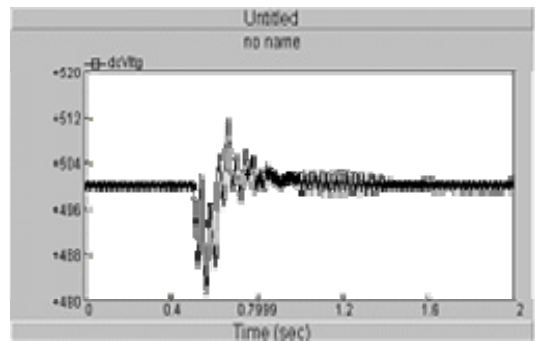

(d) DC link voltage (kV)

**Fig. 13.** Results of Case 3.

and advanced technology in EMTDC analysis. In this paper, we developed the EMTDC model of the Russia-ROK power system interconnection to which we applied VSC-

HVDC and evaluated dynamic its characteristics under various operating conditions to verify this model.

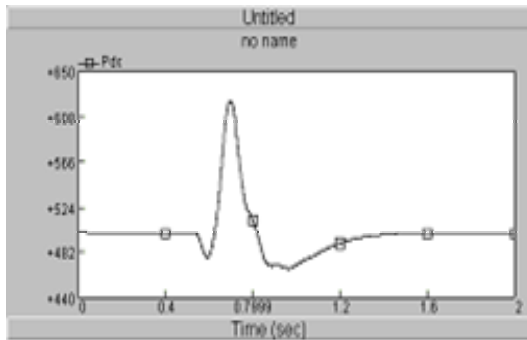

(a) Power flow in DC line (MW)

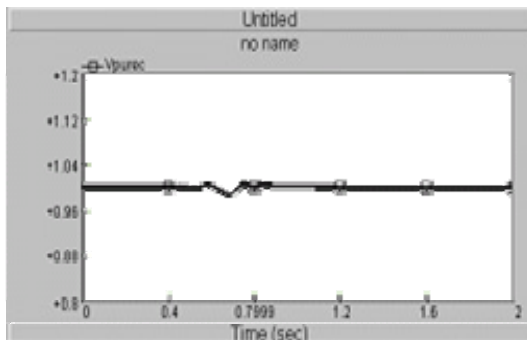

(b) AC voltage at Russia (pu)

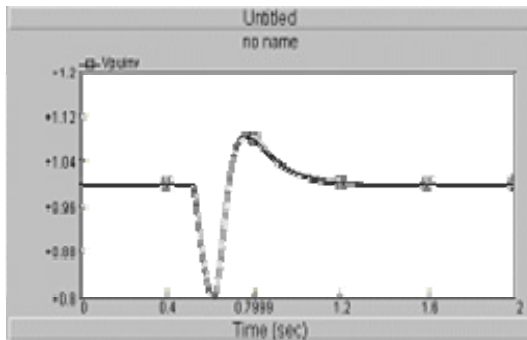

(c) AC voltage at ROK (pu)

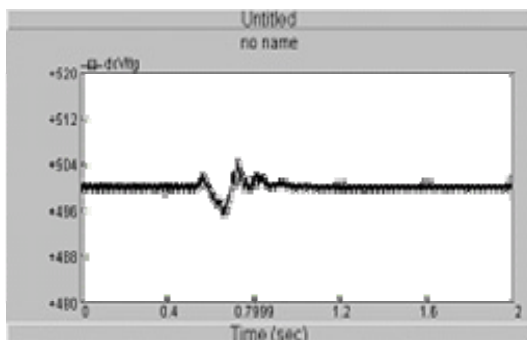

(d) DC link voltage (kV)

**Fig. 14.** Results of Case 4.

**References**

- [1] KERI, "Planning for pre-feasibility study on power system interconnection in Northeast Asia", 2002. 5.
- [2] J.Y.Yoon, H.Y. Kim, D.W. Park., presentation at UNESCAP-SOM "Perspectives for inter-country power exchange in North-East Asia", 2003. 4.
- [3] IEEE PES GM, "Korean Activities for the Northeast Asia System interconnection", J.Y.Yoon, H.Y. Kim, D.W. Park, 2003. 7
- [4] Gamolya N.D., Filatova A.D. "Interstate Electric Ties in the Far East of Russia", Presented at UN ESCAP Meeting in Vladivostok, April 7-10, Russia, 2003.
- [5] R. Jotten, J.P.Bowles, G.Liss, C.J.B. Martin, and E. Rumpf, "Control in HVDC Systems, The State of the Art, Part I: Two Terminal Systems", CIGRE Paper 14-10, 1978.
- [6] Gunnar Asplund, Kjell Eriksson, Kjell Svensson, "DC Transmission based on Voltage Source Converter", CIGRE SC14 Colloquium, 1997.
- [7] J. VanCoevering, J.P.Stovall, etc, "The Next Generation of HVDC-Needed R&D, Equipment Costs, and Cost Comparisons", PTI Advance Course Notes, 1996.
- [8] Grunbaum R, Halvarsson B, Wilk-Wilczynski A, Facts and HVDC Light for Power system Interconnections", Power Delivery Conference, Madrid, Spain, 1999.
- [9] B. R. Andersen, L. Xu, P.J. Horton and P. Cartwright, "Topologies for VSC Transmission", Journal of Power Engineering, June, 2002.
- [10] Electranix corporation, "Advanced Modeling of HVDC/FACTS Systems and Controls with PSCAD", 2003.
- [11] Behzard Qahraman, Ebrahim Rahimi, and Aniruddha M. Gole, "An Electromagnetic Transient Simulation Model for Voltage Sourced Converter Based HVDC Transmission", CCECE, Niagara falls, May, 2004.



**Jong-yul Kim** has been with the Korea Electrotechnology Research Institute (KERI) as a Research Engineer since 2001. He received his B.S. and M.S. degrees in Electrical Engineering from Pusan National University. His research interests are the power system analysis including power conversion devices and AI applications to power system.



**Jae-young Yoon** is with the Korea Electrotechnology Research Institute (KERI). He received his B.Sc., M.Sc. and Ph.D degrees in Electrical Engineering from Busan National University. He currently manages a research project, application of HTS-equipment and also plays a key role in the research project related to the Northeast Asia Power System Interconnection, which includes North Korea.



**Ho-yong Kim** has been with the Korea Electrotechnology Research Institute (KERI) as a Principle Research Engineer since 1986. He received his B.S. degree from Seoul National University, Korea in 1979 and his M.S. and Ph.D. degrees from the University of Texas at Austin, USA in 1982 and 1985, respectively. His main research areas are distribution automation, AI applications to power systems and Power System Interconnection.